

VDIC EEPROM

VDEE8M32XS64XX8C250 USER MANUAL

Version : A5

Document NO.: ORBITA/SIP-VDEE8M32XS64XX8C250-USM-01

Zhuhai Orbita Aerospace Science & Technology Co. , Ltd.

Add: Orbita Tech Park, NO.1 Baisha Road, Tangjia Dong ` an,

Zhuhai, Guangdong, China 519080

Tel: +86-756-3391979 Fax: +86-756-3391980

Contents

1	Description	1
2	Features	1
3	Block Diagram	2
4	Pin Descriptions	3
5	Command Operation	4
5.1	Absolute Maximum Ratings	4
5.2	Recommended DC Operating Conditions	4
5.3	DC Characteristics (VCC = 4.5 V to 5.5 V)	4
6	Typical Application	5
7	Ordering Information	6
8	Package Dimensions	7
9	REVISION HISTORY	8

VDIC-EEPROM

5.0V 256K× 32bit

1 Description

The VDEE8M32XS64XX8C250 is a 256K× 32bit Electrically Erasable and Programmable CMOS ROM. It is organized as two banks of 4Mbit(128k×32). Each bank has 32-bit interface and is selected with specific #CE. All other signals are common to the eight EEPROM 1Mbit. The device is manufactured using well known SIP technology. It is particularly well suited for use in high reliability, high performance and high density system applications.

The VDEE8M32XS64XX8C250 is packaged in a 64 pins SOP

2 Features

- Single 5.0V supply: 4.5 V to 5.5 V
- Access time: 150 ns (max)
- Power dissipation
 - Active: 80 mW/MHz, (typ)
 - Standby: 880 μW (max)
- On-chip latches: address, data, #CE, #OE, #WE
- Automatic byte write: 15 ms (max)
- Automatic page write (128 bytes): 15 ms (max)
- Data polling and RDY/#Busy
- Data protection circuit on power on/off
- Conforms to JEDEC byte-wide standard
- Reliable CMOS with MNOS cell technology
- 10⁴erase/write cycles (in page mode)
- 10 years data retention
- Software data protection
- Write protection by #RES pin

3 Block Diagram

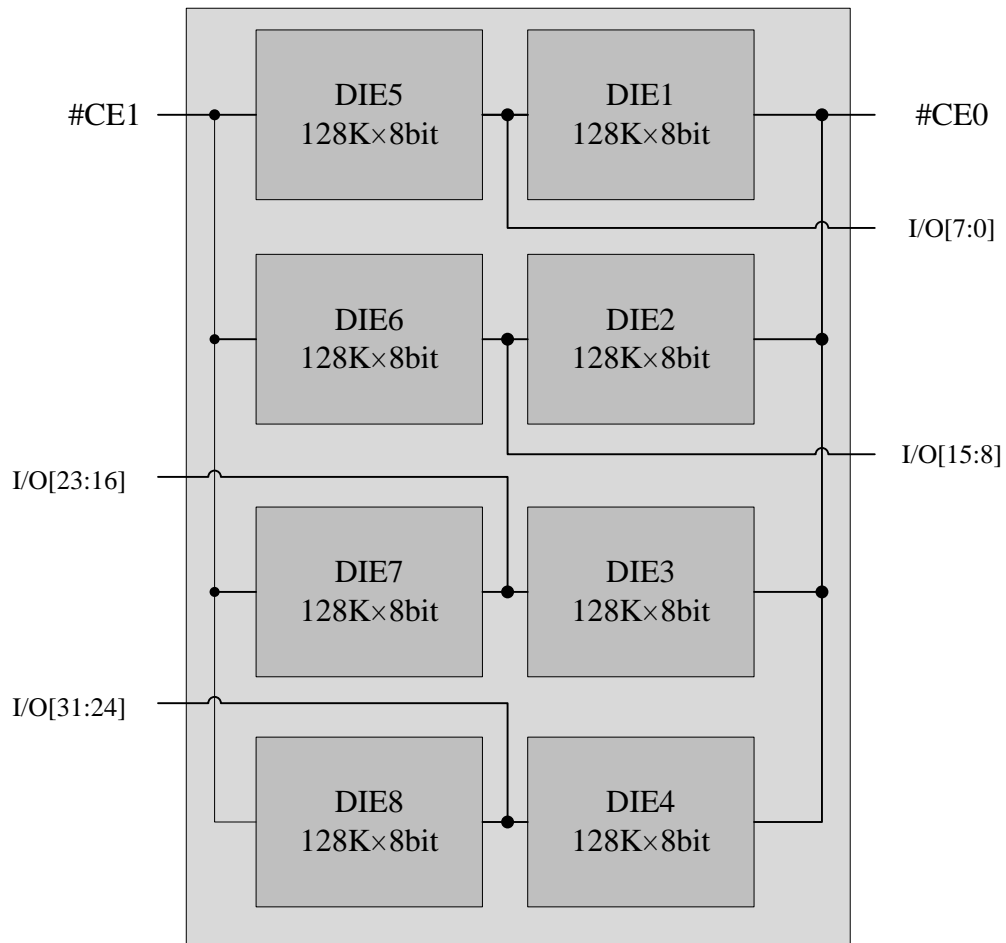

4 Pin Descriptions

Pin Id	Pin #		Pin Id
A11	1	64	I/O24
A9	2	63	I/O16
A8	3	62	I/O8
A4	4	61	I/O0
A5	5	60	I/O25
A6	6	59	I/O17
A7	7	58	I/O9
A12	8	57	I/O1
A14	9	56	I/O26
A16	10	55	I/O18
RDY/#BUSY	11	54	I/O10
VCC	12	53	I/O2
VCC	13	52	I/O27
VCC	14	51	I/O19
VCC	15	50	I/O11
A15	16	49	I/O3
#RES	17	48	I/O28
#WE	18	47	I/O20
A13	19	46	I/O12
A0	20	45	I/O4
A1	21	44	I/O29
A2	22	43	I/O21
A3	23	42	I/O13
VSS	24	41	I/O5
VSS	25	40	I/O30
VSS	26	39	I/O22
VSS	27	38	I/O14
#CE0	28	37	I/O6
NC	29	36	I/O31
#CE1	30	35	I/O23
A10	31	34	I/O15
#OE	32	33	I/O7

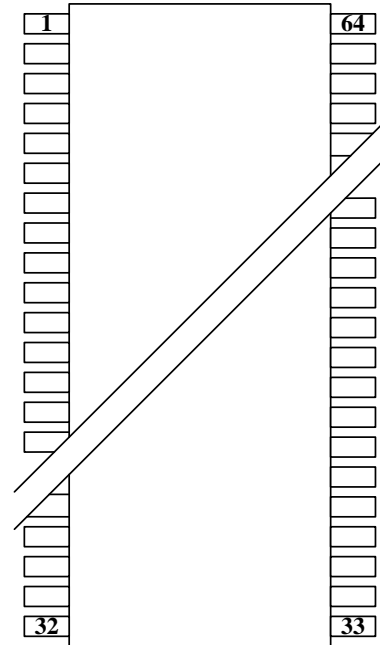

Name	Function
A0~A16	Address Input..
I/O0- I/O31	Data Input/Output Ports. 32 bit-directional ports are used to read data from or write data into the EEPROM.
#CE0	Die Enable Input .When #CEn is Low, the command input cycle becomes valid.
#CE1	When #CEn is High, all inputs are ignored.
RDY/#BUSY	Ready busy.
#RES	Reset
#OE	Output enable.
#WE	Write Enable Input.Enables write operation.
VCC	Power supply
VSS	Ground

5 Command Operation

5.1 Absolute Maximum Ratings

Parameter	Symbol	Value	Unit
Supply voltage relative to V_{SS}	V_{CC}	-0.6 to +7.0	V
Input voltage relative to V_{SS}	V_{IN}	-0.5 to +7.0	V
Operating temperature range	T_{OPR}	-55 to +125	°C
Storage temperature range	T_{STG}	-65 to +150	°C
Power Dissipation	P_D	2.0	W

5.2 Recommended DC Operating Conditions

Parameter	Symbol	Min	Typ	Max	Unit
Supply voltage	V_{CC}	4.5	5.0	5.5	V
	V_{SS}	0	0	0	V
Input voltage	V_{IL}	-0.3	-	0.8	V
	V_{IH}	2.2	-	$V_{CC}+0.3$	V
	V_H	$V_{CC}-0.5$	-	$V_{CC}+1.0$	V

5.3 DC Characteristics ($V_{CC} = 4.5\text{ V to }5.5\text{ V}$)

Parameter	Symbol	Test conditions	min.	max.	Unit
Output voltage low level	VOL	$V_{CC}=4.5\text{V}$, $I_{OL} = 2.1\text{mA}$	—	0.4	V
Output voltage high level	VOH	$V_{CC}=4.5\text{V}$, $I_{OH}= -400\mu\text{A}$	2.4	—	V

6 Typical Application

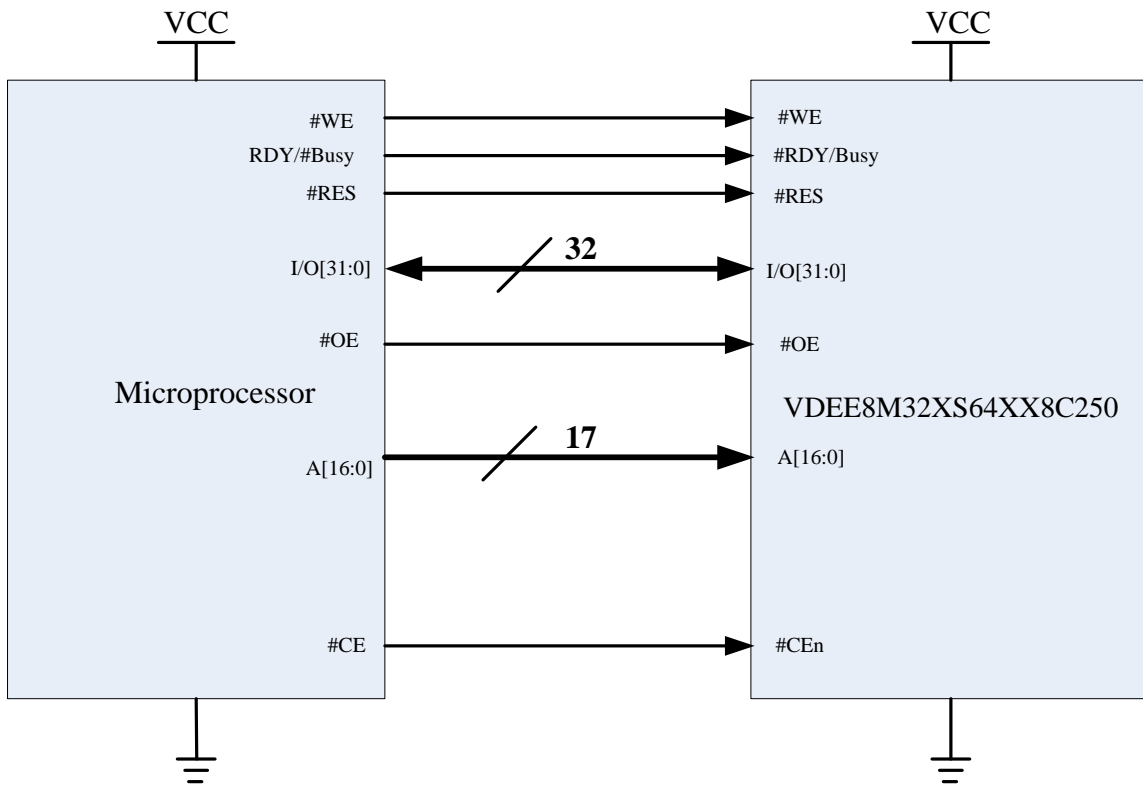

7 Ordering Information

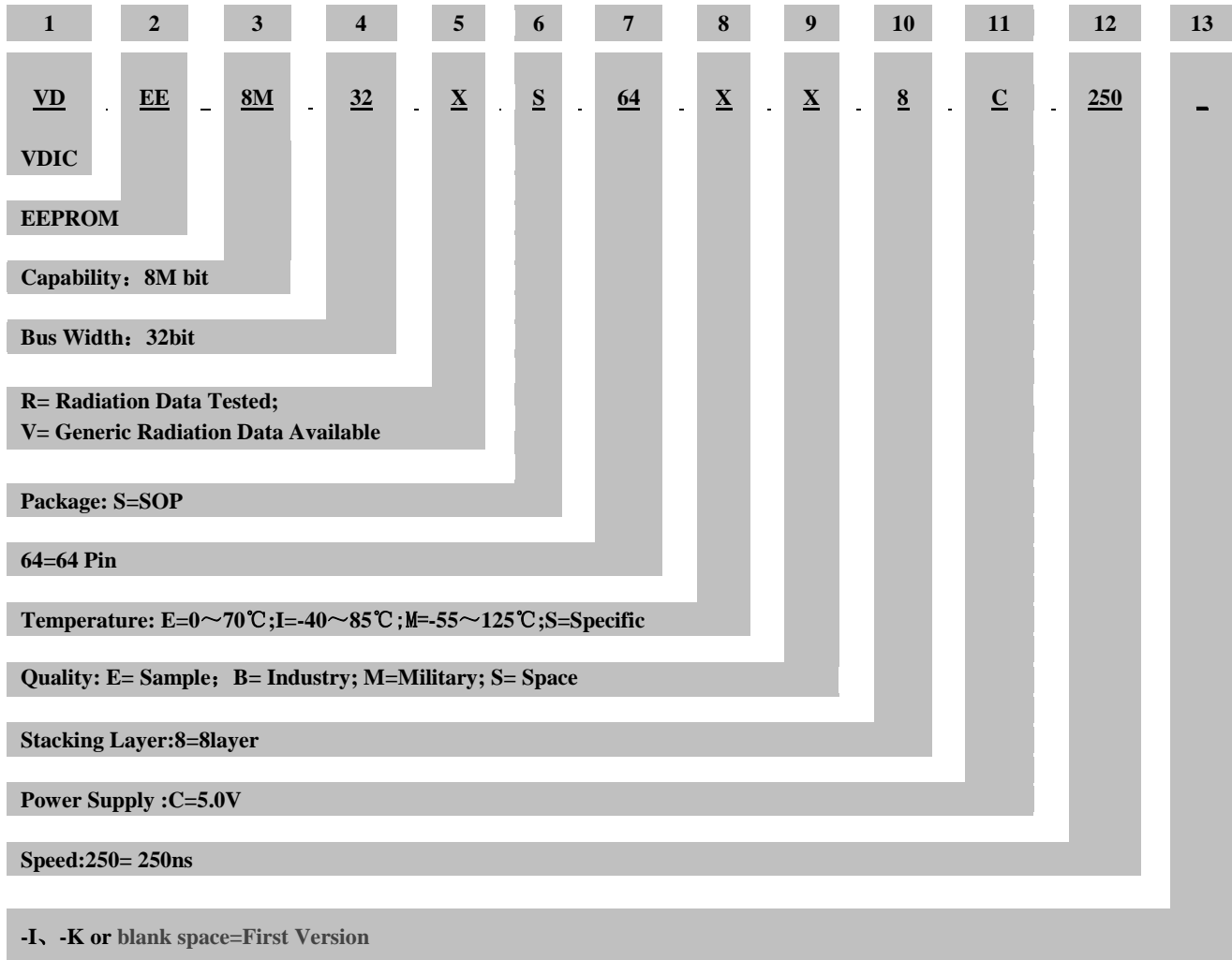

Part Number	Capacity (bit)	Bus Width (bit)	Radiation			Packaging	Temperature (°C)
			TID ¹	SEL ²	SEU ³		
VDEE8M32VS64EE8C250	8M	32	-	-	-	SOP64	0 ~ + 70
VDEE8M32VS64IB8C250	8M	32	-	-	-	SOP64	-40 ~ + 85
VDEE8M32VS64MB8C250	8M	32	-	-	-	SOP64	-55 ~ + 125
VDEE8M32VS64MM8C250	8M	32	-	-	-	SOP64	-55 ~ + 125
VDEE8M32RS64MS8C250	8M	32	30	99.8	25	SOP64	-55 ~ + 125

¹ TID: Total Dose (Krad(Si))

² SEL: LET Threshold (Mev.cm²/mg)

³ SEU:SEU Threshold (Mev.cm²/mg)

8 Package Dimensions

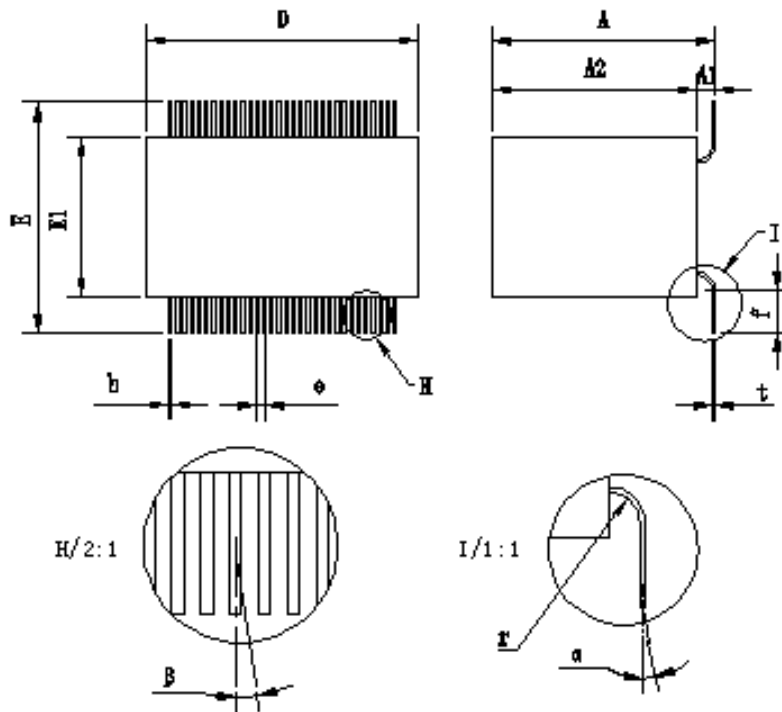

	Min	Max
A	14.90	15.80
A2	13.70	14.50
D	18.50	18.90
E	15.80	16.20
E1	10.80	11.20
f	2.9	
b	0.25	
e	0.5	
r	1.0	
t	0.2	
alpha	≤3°	
beta	≤3°	
NOTE : 1.U int : mm		
2. A1= A - A2		

9 REVISION HISTORY

Revision	Date	Description of Change
A0	Nov 3,2015	First Created
A1	Mar 14,2016	Modified the PIN DESCRIPTIONS
A2	Aug 23,2016	Modified the ORDERING INFORMATION
A3	Jan 9,2017	Modified the PACKAGE DIMENSIONS
A4	Oct.25,2017	Changed company's name to Zhuhai Orbita Aerospace Science & Technology Co., Ltd
A5	Mar 16,2018	Add or reduce chapters