

VDIC EEPROM

VDEE4M08XS40XX4V250 USER MANUAL

Version : B1

Document NO.: ORBITA/SIP-VDEE4M08XS40XX4V250-USM-01

Zhuhai Orbita Aerospace Science & Technology Co. , Ltd.

Add: Orbita Tech Park, NO.1 Baisha Road, Tangjia Dong ` an,

Zhuhai, Guangdong, China 519080

Tel: +86-756-3391979 Fax: +86-756-3391980

Contents

1	DESCRIPTION.....	1
2	FEATURES.....	1
3	BLOCK DIAGRAM.....	2
4	PIN DESCRIPTIONS	2
5	COMMAND OPERATION	3
5.1	ABSOLUTE MAXIMUM RATINGS	3
5.2	RECOMMENDED DC OPERATING CONDITIONS	3
5.3	DC CHARACTERISTICS ($V_{CC} = 2.7\text{ V TO }3.6\text{ V}$).....	3
6	TYPICAL APPLICATION.....	4
7	ORDERING INFORMATION	5
8	PACKAGE DIMENSIONS	6
9	REVISION HISTORY	7

VDIC-EEPROM

3.3V 512K × 8bit

1 Description

The VDEE4M08XS40XX4V250 is a 512K×8bit. Electrically Erasable and Programmable CMOS ROM. It is organized as four dies of 1Mbit. Each die has 8-bit interface and is selected with specific #CEn. All other signals are common to the four EEPROM 1Mbit. The device is manufactured using well known SIP technology. It is particularly well suited for use in high reliability, high performance and high density system applications.

The VDEE4M08XS40XX4V250 is packaged in a 40 pins SOP.

2 Features

- Single 3.3 V supply: 2.7 V to 3.6 V
- Access time: 250 ns (max)
- Power dissipation
 - Active: 80 mW/MHz, (typ)
 - Standby: 440 μW (max)
- On-chip latches: address, data, #CEn, #OE, #WE
- Automatic byte write: 15 ms (max)
- Automatic page write (128 bytes): 15 ms (max)
- Data polling and RDY/#Busy
- Data protection circuit on power on/off
- Conforms to JEDEC byte-wide standard
- Reliable CMOS with MNOS cell technology
- 10⁴erase/write cycles (in page mode)
- 10 years data retention
- Software data protection
- Write protection by #RES pin

3 Block Diagram

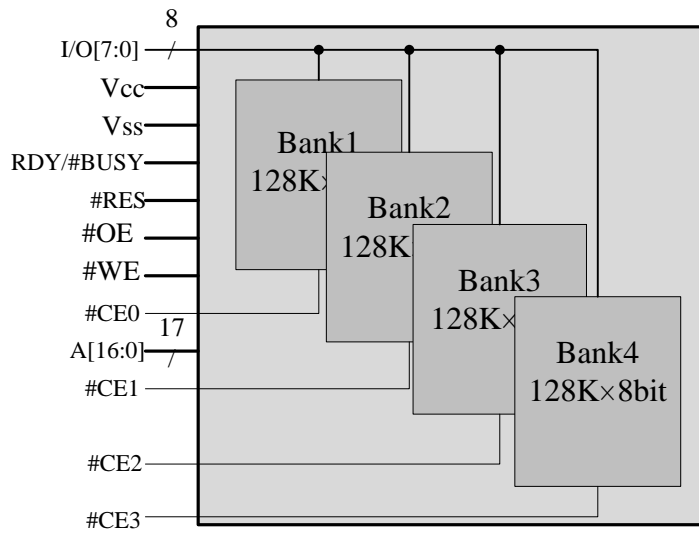

4 Pin Descriptions

Pin Id	Pin #		Pin Id
VSS	1	40	#CE2
NC	2	39	#CE1
A11	3	38	#OE
A9	4	37	A10
A8	5	36	#CE0
A13	6	35	I/O7
#WE	7	34	I/O6
#RES	8	33	I/O5
A15	9	32	I/O4
VCC	10	31	I/O3
RDY/#BUSY	11	30	VSS
A16	12	29	I/O2
A14	13	28	I/O1
A12	14	27	I/O0
A7	15	26	A0
A6	16	25	A1
A5	17	24	A2
A4	18	23	A3
NC	19	22	#CE3
NC	20	21	NC

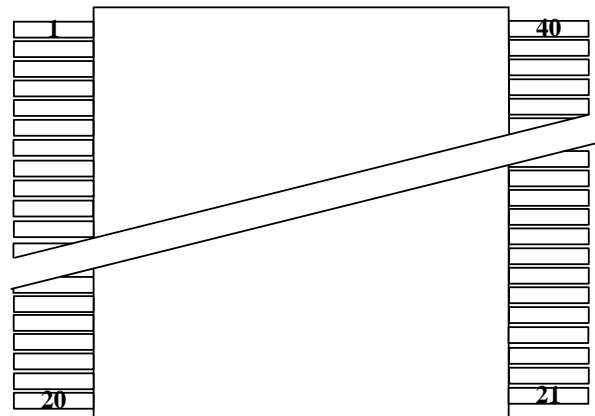

Name	Function
A0~A16	Address Input..
I/O0- I/O7	Data Input/Output Ports. 8 bit-directional ports are used to read data from or

	write data into the EEPROM.
#CE0 (Die1)	Die Enable Input .When #CEn is Low, the command input cycle becomes valid. When #CEn is High, all inputs are ignored.
#CE1 (Die2)	
#CE2 (Die3)	
#CE3 (Die4)	
RDY/#BUSY	Ready busy.
#RES	Reset input.
#OE	Output enable.
#WE	Write Enable Input.Enables write operation.
VCC	Power supply
VSS	Ground
NC	No connection This pin is recommended to be left No Connection on the device.

5 Command Operation

5.1 Absolute Maximum Ratings

Parameter	Symbol	Value	Unit
Supply voltage relative to V _{SS}	V _{CC}	-0.6 to +7.0	V
Input voltage relative to V _{SS}	V _{IN}	-0.5 to +7.0	V
Operating temperature range	T _{OPR}	-55 to +125	°C
Storage temperature range	T _{STG}	-65 to +150	°C
Power Dissipation	P _D	2	W

5.2 Recommended DC Operating Conditions

Parameter	Symbol	Min	Typ	Max	Unit
Supply voltage	V _{CC}	2.7	3.3	3.6	V
	V _{SS}	0	0	0	V
Input voltage	V _{IL}	-0.3	-	0.8	V
	V _{IH}	1.9	-	V _{CC} +0.3	V
	V _H	V _{CC} -0.5	-	V _{CC} +1.0	V

5.3 DC Characteristics (V_{CC} = 2.7 V to 3.6 V)

Parameter	Symbol	Test conditions	min.	max.	Unit
-----------	--------	-----------------	------	------	------

Parameter	Symbol	Test conditions	min.	max.	Unit
Output voltage low level	VOL	V _{CC} =2.7V , I _{OL} = 2.1mA	—	0.4	V
Output voltage high level	VOH	V _{CC} =2.7V , I _{OH} = -400uA	2.16	—	V

6 Typical Application

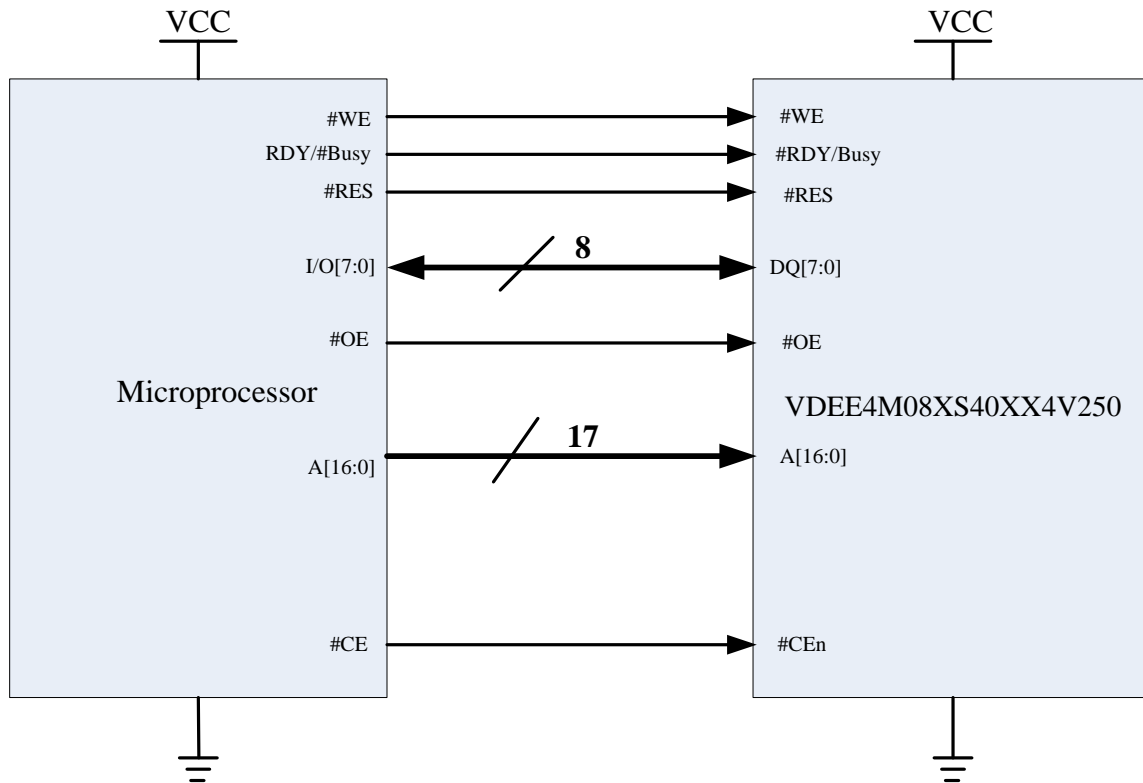

7 Ordering Information

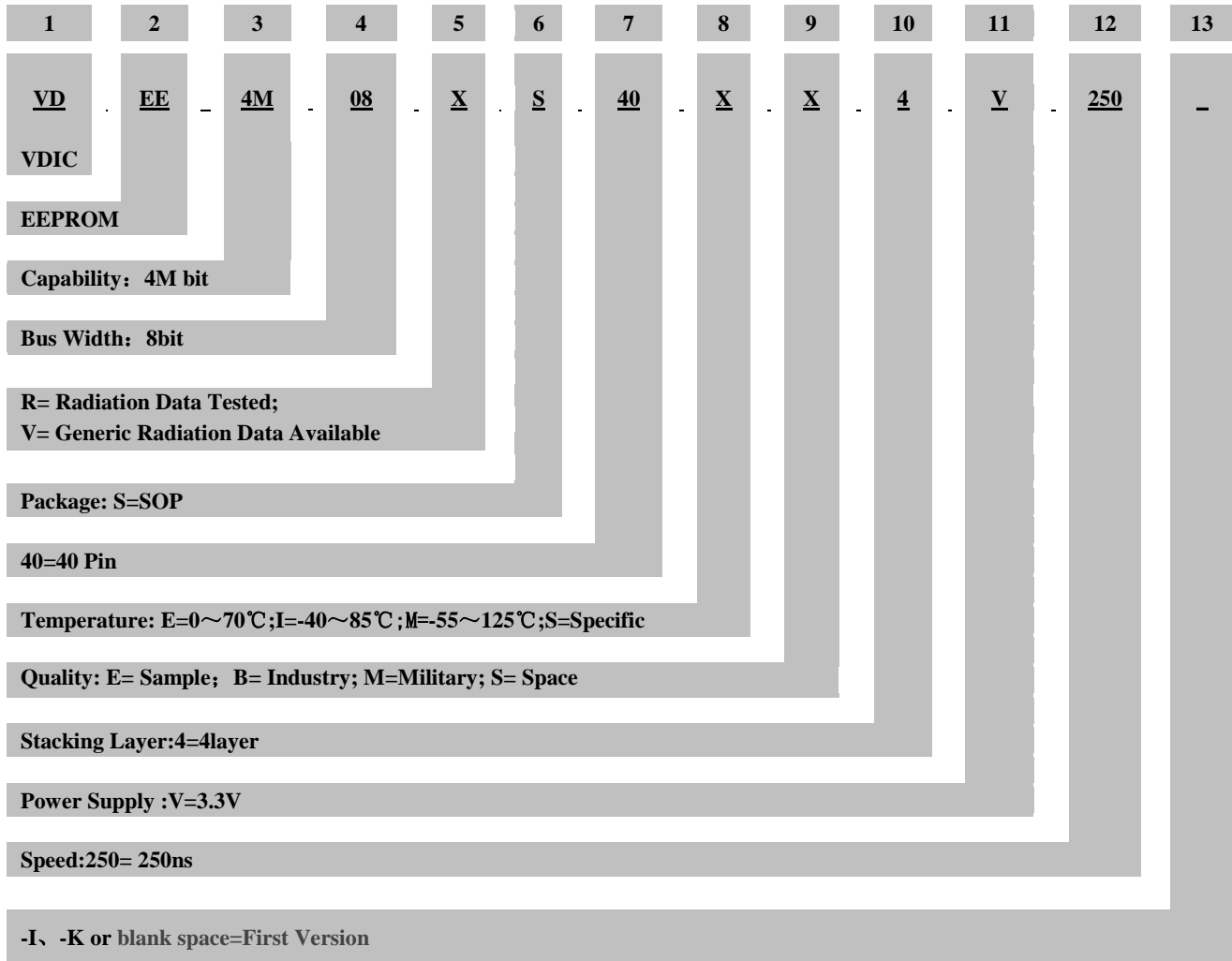

Part Number	Capacity (bit)	Bus Width (bit)	Radiation			Packaging	Temperature (°C)
			TID ¹	SEL ²	SEU ³		
VDEE4M08VS40EE4V250	4M	8	-	-	-	SOP40	0 ~ + 70
VDEE4M08VS40IB4V250	4M	8	-	-	-	SOP40	-40 ~ + 85
VDEE4M08VS40MB4V250	4M	8	-	-	-	SOP40	-55 ~ + 125
VDEE4M08VS40MM4V250	4M	8	-	-	-	SOP40	-55 ~ + 125
VDEE4M08RS40MS4V250	4M	8	30	99.8	25	SOP40	-55 ~ + 125

¹ TID: Total Dose (Krads(Si))

² SEL: LET Threshold (Mev.cm²/mg)

³ SEU:SEU Threshold (Mev.cm²/mg)

8 Package Dimensions

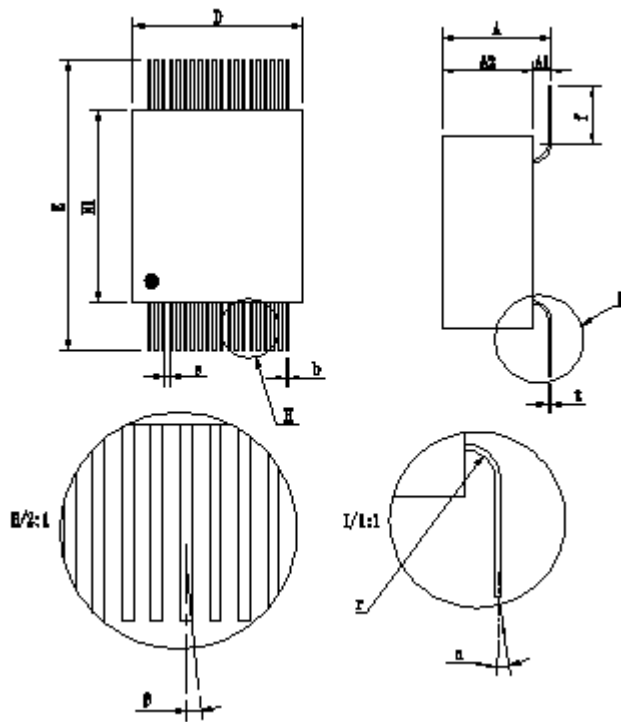

	Min	Max
A	7.40	7.90
A2	6.20	6.60
D	11.50	11.90
E	19.80	20.20
E1	13.00	13.40
f	3.98	
b	0.25	
e	0.5	
r	1.0	
t	0.2	
α	≤3°	
β	≤3°	
NOTE : 1.U int : mm		
2. A1= A - A2		

9 REVISION HISTORY

Revision	Date	Description of Change
A0	Nov 3,2015	First Created
A1	Mar 14,2016	Modified the PIN DESCRIPTIONS
A2	Aug 23,2016	Modified the ORDERING INFORMATION
A3	Jan 9,2017	Modified the PACKAGE DIMENSIONS
A4	Oct.25,2017	Changed company's name to Zhuhai Orbita Aerospace Science & Technology Co., Ltd
A5	Dec.28,2017	Modified Electrical Specifications
B0	Jan 5.2018	Modified Features.
B1	Mar 16,2018	Add or reduce chapters