

# **VDIC MAGNETORESISTIVES RANDOM ACCESS MEMORY**

## **VDMR1M08XS44XX1V35 USER MANUAL**

**Version : B2**

**Document NO. : ORBITA/SIP- VDMR1M08XS44XX1V35 -USM-01**

**Zhuhai Orbita Aerospace Science & Technology Co. , Ltd.**

**Add: Orbita Tech Park, NO.1 Baisha Road, Tangjia Dong ` an,**

**Zhuhai, Guangdong, China 519080**

**Tel: +86-756-3391979 Fax: +86-756-3391980**

## Contents

1	DESCRIPTION.....	1
2	FEATURES.....	1
3	BLOCK DIAGRAM.....	2
4	PIN DESCRIPTIONS.....	2
5	ELECTRICAL SPECIFICATIONS.....	3
5.1	ABSOLUTE MAXIMUM RATINGS.....	3
5.2	RECOMMENDED DC OPERATING CONDITIONS.....	3
5.3	DC ELECTRICAL CHARACTERISTICS.....	4
6	TYPICAL APPLICATION.....	4
7	ORDERING INFORMATION.....	5
8	PACKAGE DIMENSIONS.....	6
9	REVISION HISTORY.....	7

# VDIC-MRAM

## HIGH-SPEED 3.3V 128K×8bit

## MAGNETORESISTIVES RANDOM ACCESS MEMORY

### 1 DESCRIPTION

The VDMR1M08XS44XX1V35 is a 1,048,576-bit high-speed access time, high-density Magnetoresistive Random Access Memory device. Manufactured with VDIC Very Dense SiP technology, this device stacks 1-Mbit MRAM dies. It is organized as one independent dies of 128K x 8bit wide data interface.

The VDMR1M08XS44XX1V35 offers MRAM compatible 35ns read/write timing with unlimited endurance. Data is always non-volatile for greater than 20-years. Data is automatically protected on power loss by low-voltage inhibit circuitry to prevent writes with voltage out of specification. The VDMR1M08XS44XX1V35 is the ideal memory solution for applications that must permanently store and retrieve critical data and programs quickly.

The VDMR1M08XS44XX1V35 has one die. It can be selected with dedicated #CE. Low interconnect parasitic capacitance of the stacking technology, by reducing the connection length, allows this MRAM module to be useful for a variety of high bandwidth, high performance and high density memory system applications.

### 2 FEATURES

- Fast 35ns Read/Write Cycle
- SRAM Compatible Timing, Uses Existing SRAM Controllers Without Redesign
- Unlimited Read & Write Endurance
- Data Always Non-volatile for >20-years
- One Memory Replaces Flash, SRAM, EEPROM and BBSRAM in a system for simpler, more efficient design
- Stack of one 1Mbit MRAM
- Organized as 1 die of 128K x 8 bit memory
- One independent Die Select
- 3.3 Volt Power Supply
- Automatic Data Protection on Power Loss
- 44-lead SOP package

### 3 BLOCK DIAGRAM

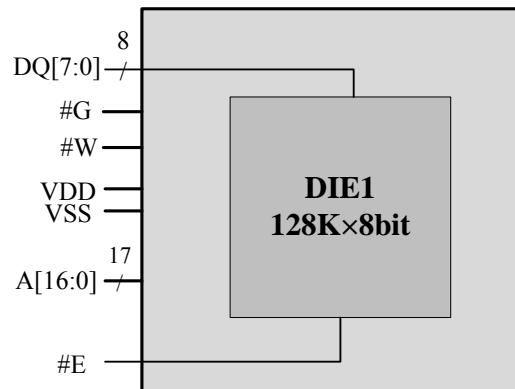

Figure 1 Block diagram

### 4 PIN DESCRIPTIONS

Pin Id	Pin #		Pin Id
DC	1	44	DC
NC	2	43	NC
A0	3	42	DC
A1	4	41	NC
A2	5	40	NC
A3	6	39	A16
A4	7	38	A15
#E	8	37	#G
DQ0	9	36	DQ7
DQ1	10	35	DQ6
VDD	11	34	VSS
VSS	12	33	VDD
DQ2	13	32	DQ5
DQ3	14	31	DQ4
#W	15	30	DC
A5	16	29	A14
A6	17	28	A13
A7	18	27	A12
A8	19	26	A11
A9	20	25	A10
DC	21	24	DC
DC	22	23	DC

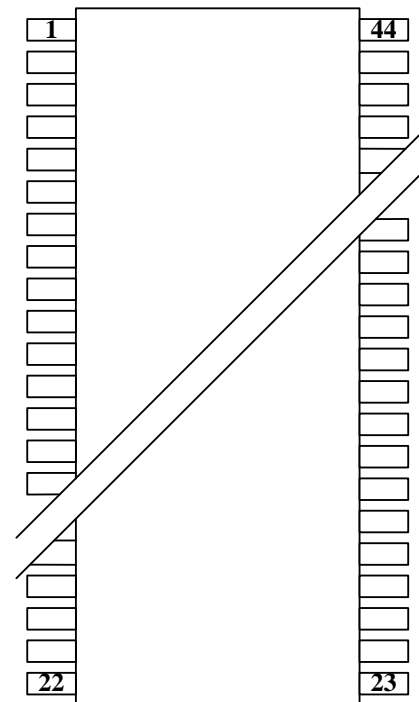

Figure 2 Pin configuration

Table 1 Pin description

Pin	Name	Function
#E	Chip Enable	Disables or enables memory operation
A0 ~ A16	Address	17-bit addresses
#W	Write enable	Enables write operation common to all memory dies
#G	Output enable	Enables data output common to all memory dies
DQ0~ DQ7	Data input/output	Data inputs/outputs 8-bit wide bus
VDD/VSS	Power supply/ground	Power and ground for the input/output buffers and core logic.
NC	No connection	These pins are recommended to be left No Connection on the device.
DC	Do not connect	These pins do not connect

## 5 ELECTRICAL SPECIFICATIONS

### 5.1 ABSOLUTE MAXIMUM RATINGS

This device contains circuitry to protect the inputs against damage caused by high static voltages or electric fields; however, it is advised that normal precautions be taken to avoid application of any voltage greater than maximum rated voltages to these high-impedance (Hi-Z) circuits.

The device also contains protection against external magnetic fields. Precautions should be taken to avoid application of any magnetic field more intense than the maximum field intensity specified in the maximum ratings.

Table 2 Absolute maximum ratings

Parameter	Symbol	Maximum ratings	Unit
Supply Voltage	V <sub>DD</sub>	-0.5 ~ 4.0	V
Voltage on any pin relative to V <sub>SS</sub>	V <sub>IN</sub>	-0.5 ~ V <sub>DD</sub> +0.5	V
Operating Temperature Range	T <sub>OPR</sub>	-55 ~ +95	°C
Storage temperature	T <sub>STG</sub>	-55 ~ +105	°C
Power dissipation	P <sub>D</sub>	0.6	W

### 5.2 RECOMMENDED DC OPERATING CONDITIONS

Table 3 Recommended DC operating condition

Parameter	Symbol	Min	Typ	Max	Unit
Power Supply voltage	V <sub>DD</sub>	3.0	3.3	3.6	V
Input logic high voltage	V <sub>IH</sub>	2.2	--	V <sub>DD</sub> +0.3	V
Input logic low voltage	V <sub>IL</sub>	-0.5	--	0.8	V
Write inhibit voltage	V <sub>WI</sub>	2.5	2.7	3.0	V

5.3 DC ELECTRICAL CHARACTERISTICS

Table 4 DC electrical characteristics

Parameter	Symbol	Test Conditions	Min	Max	Unit
Output voltage low level	V <sub>OL</sub>	I <sub>OL</sub> = +4mA	—	0.4	V
Output voltage high level	V <sub>OH</sub>	I <sub>OL</sub> = -4mA	2.4	—	V

6 TYPICAL APPLICATION

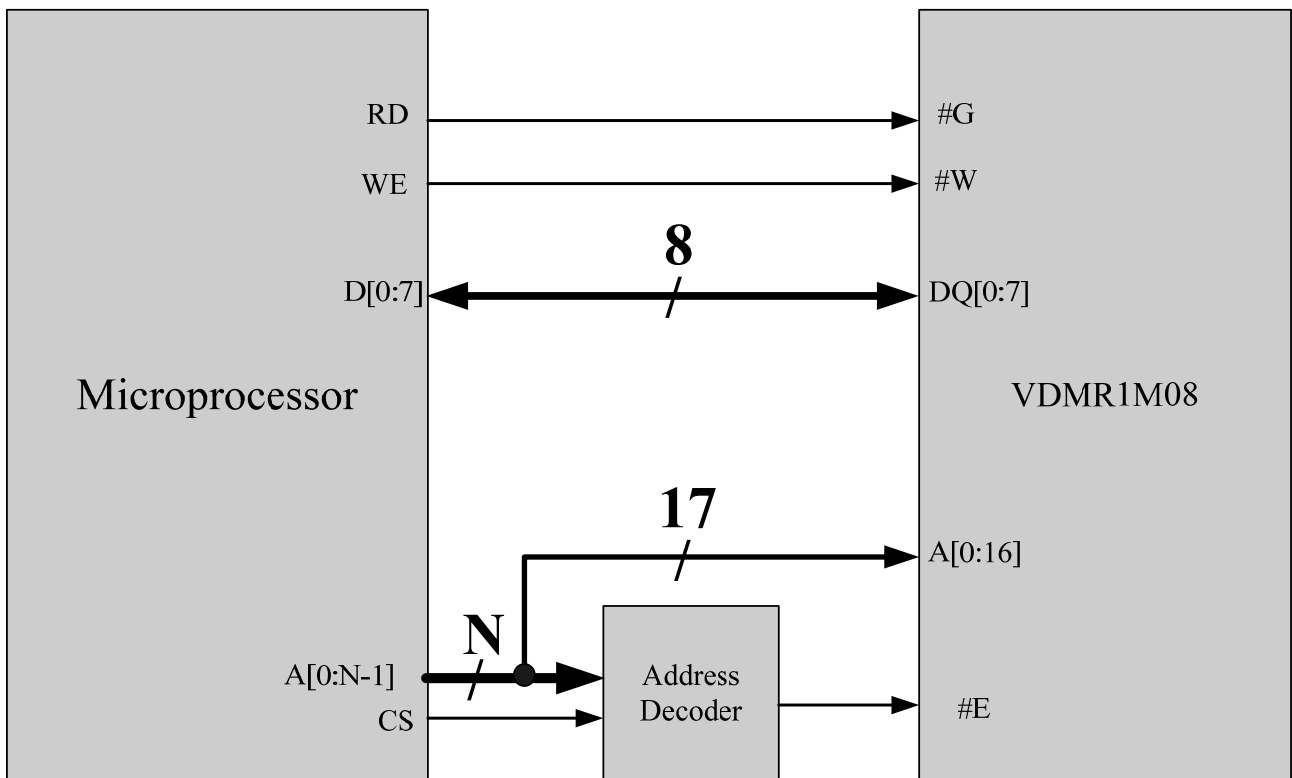

Figure 3 Typical application

## 7 ORDERING INFORMATION

1	2	3	4	5	6	7	8	9	10	11	12	13
<u>VD</u>	<u>MR</u>	<u>1M</u>	<u>08</u>	<u>X</u>	<u>S</u>	<u>44</u>	<u>X</u>	<u>X</u>	<u>1</u>	<u>V</u>	<u>35</u>	<u>-</u>
VDIC												
MRAM												
Capability: 1M bit												
Bus Width: 8bit												
R= Radiation Data Tested; V= Generic Radiation Data Available												
Package: SOP												
Pin Quantity: 44 Pin												
Temperature: E=0~+70°C; I=-40~+85°C; S=-55~+95°C												
Quality: E= Sample; B= Industry; S= Space												
Stacking Layer: 1 layer												
Power Supply: 3.3V												
Speed: 35ns												
Version: First Version												

Table 5 Ordering information

Part Number	Capacity (bit)	Bus Width (bit)	Radiation			Packaging	Temperature ( °C )
			TID <sup>1</sup>	SEL <sup>2</sup>	SEU <sup>3</sup>		
VDMR1M08VS44EE1V35	1M	8	-	-		SOP44	0 ~ +70
VDMR1M08VS44IB1V35	1M	8	-	-		SOP44	-40 ~ +85
VDMR1M08RS44SS1V35	1M	8	>50	>75	>15	SOP44	-55 ~ +95

<sup>1</sup> TID: Total Dose (Krad(Si))

<sup>2</sup> SEL: LET Threshold (Mev.cm<sup>2</sup>/mg)

<sup>3</sup> SEU:SEU Threshold (Mev.cm<sup>2</sup>/mg)

### 8 PACKAGE DIMENSIONS

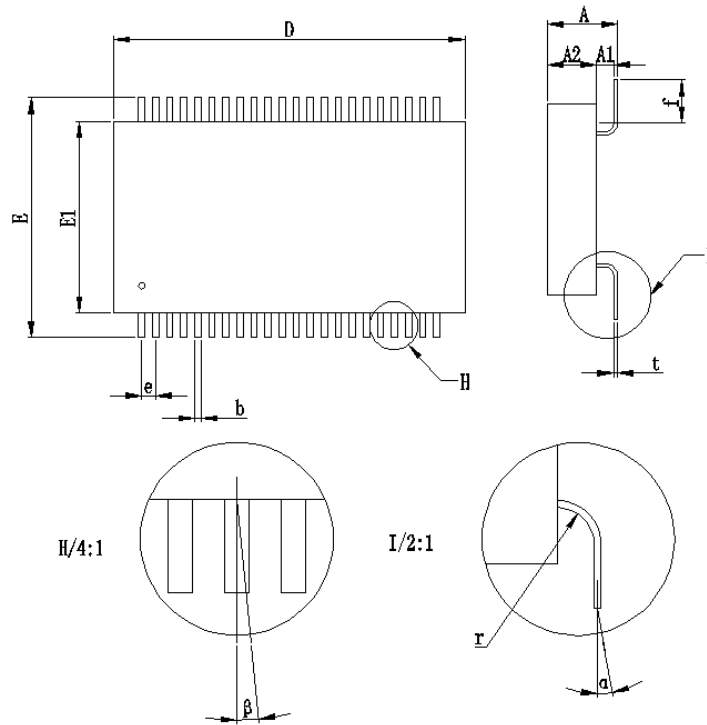

Figure 4 Package dimensions

Table 6 Dimensions information

	Min	Max
A	3.70	4.40
A2	2.50	3.10
D	19.80	20.20
E	13.40	13.80
E1	10.80	11.20
f	2.00	
b	0.35	
e	0.80	
r	1.00	
t	0.20	
α	≤3°	
β	≤3°	
NOTE: 1. Unit: mm 2. A1=A - A2		



## 9 REVISION HISTORY

**Table 7 Revision history**

Revision	Date	Description of Change
A0	Nov 3,2015	First Created
A1	Mar 14,2016	Modified the PIN DESCRIPTIONS
A2	Aug 23,2016	Modified the ORDERING INFORMATION
A3	Jan 9,2017	Modified the PACKAGE DIMENSIONS
A4	Oct.25,2017	Changed company's name to Zhuhai Orbita Aerospace Science & Technology Co., Ltd
A5	Mar 9,2018	Add or reduce chapters
B0	May 22, 2018	Modified Operating Temperature Range and Storage temperature.
B1	Jun 18,2019	Change Pin Descriptions
B2	Mar 21,2020	Update TID and SEE